

# Autocorrelator

MODEL AA-10DM

---

# 1.

## INTRODUCTION

The autocorrelation technique is the most common method used to determine laser pulse width characteristics on a femtosecond time scale.

The basic optical configuration of the autocorrelator is similar to that of an interferometer (Figure.1). An incoming pulse train is split into two beams of equal intensity. An adjustable optical delay is inserted into one of the arms. The two beams are then recombined within a nonlinear material (semiconductor) for two photon absorption (TPA). The incident pulses directly generate a nonlinear TPA photocurrent in the semiconductor, and the detection of this photocurrent as a function of interferometer optical delay between the interacting pulses yields the pulse autocorrelation function. The TPA process is polarization-independent and non-phasematched, simplifying alignment.

The two beams propagate in a collinear fashion (interferometric configuration). This configuration results in an autocorrelation signal that is on top of a constant background. This background is produced by TPA photocurrent resulting from the portions of the scan during which the pulses are not overlapped.

The AA-10DM autocorrelator has been specifically designed to measure the width of pulses from femtosecond lasers. For the measurement of laser pulses the only other item you need is an oscilloscope. Although not necessary, a storage oscilloscope is convenient when operating in the interferometric mode since it allows you to calibrate the display directly using the interference fringes that make up the pulse envelope.

## 2.

# KEY COMPONENTS

The AA-10DM autocorrelator consists of an opto-mechanical assembly and electronics:

- Beam Splitter
- Scanning block with measuring converter
- Variable Delay Line
- Focusing Mirror
- TPA-Detector with amplifier
- Delay Sensor
- Control Unit

### 3.

## SPECIFICATIONS

Pulse width	- 10fs... to 6ps
Input pulse repetition rate	- 10kHz to CW modelocked
Scan nonlinearity	- <1%
Sensitivity (P-av P-peak)	- <10(mW) <sup>2</sup>
Input polarization linear	- horizontal (vertical specify with order)
Wavelength range:	-700 - 1000nm (1000 – 1400nm Optional)
Scan rate variable	- 0,1 - 20Hz
Detection	- diode with TPA
Electrical power choices	- 100-110V(220V), 50-60 Hz
Dimension:	- optical unit – 170mmx134mmx105mm - control unit – 80mmx190mmx250mm

## 4.

# WARNING! LASER SAFETY

The protective housing of this product should always be in place during normal operation. Removal of the protective housing may expose the user to unnecessary radiation, and should be done only in accordance with specific instructions given in this manual. Be very careful executing any step of alignment. Avoid any exposure to the direct and reflected laser beams. Direct and reflected laser radiation can cause serious eye damage. Remember, that IR radiation is invisible or looks like the red radiation from a low intensity He-Ne laser. However, it is dangerous even at lowest intensity. Even diffuse reflections are hazardous. Check all reflections and provide enclosures for beam paths whenever possible.

### SAFETY CHECK LIST

- Wear protective goggles whenever possible.
- Please follow all safety instructions of your laser and use their recommendations in your work.
- Keep all beams below eye level always. Never look in the plane of propagation of the beams.
- When possible, maintain a high ambient light level in the laser operation area.
- Provide enclosures for beam paths whenever possible.

## 5.

# INSTALLATIONS AND ALIGNMENT

- 5.1 Reaching good alignment is easy if you use two external mirrors to direct the laser beam into the autocorrelator. **Input power should be <20mW!**
- 5.2 Install optical unit of the autocorrelator on the optical table horizontally at appropriate level. Use bottom screws to adjust level. Attach the unit to the table using clamps.
- 5.3 The height of the autocorrelator can be changed relative to the optical table.
- 5.4 The polarization of the laser input to the autocorrelator must be horizontal. (Vertical –optional).
- 5.5 Direct laser beam through the aperture A1 onto the centre of the mirror M2 (through beam splitter BS) (Figure.2). For visible beams, this alignment can be done visually; for infrared beams, a viewer should be used.
- 5.6 Move the correlator to direct reflected beam (from M2) nearly back to the center of the aperture A1 (The beam reflected exactly back can cause feedback in the laser). The Autocorrelator has been aligned at factory. Under careful transportation conditions you can try to continue alignment from 5.15.
- 5.7 Adjust beam splitter (BS) to direct beam (reflected from M2 and BS) to the center of aperture A2.
- 5.8 Direct beam reflected from M1 to the center of A2 too. If the beam reflected from the M2 propagates far from the center of A2 or M2, you should change the direction of the input beam with external mirrors or turn autocorrelator as a whole. Repeat the above mentioned procedure.
- 5.9 Remove M3 with holder.
- 5.10 Place white screen at 30 - 50 cm distance from the autocorrelator and watch spots of light reflected from M1 and M2.
- 5.11 Adjust BS and M1 to reach coincidence of spots from two beams on the screen.
- 5.12 Watch spot movement while adjusting mirror M1 with smooth stepping of the micrometric screw (One step  $\leq 10\mu\text{m}$ ). Interferometric fringes will appear when arms of the autocorrelator become equal. The picture should have

good contrast and no more than one interferometric maximum should be watched.

- 5.13 Place M3 mount into the autocorrelator.
- 5.14 Adjust M3 to direct beam onto the sensitive area of photodiode (PD).
- 5.15 Connect optical unit to terminal "EXT" at rear panel of control unit.
- 5.16 For details we suggest you consult the Optical Delay Control Unit User Manual (see Appendix A).
- 5.17 Connect oscilloscope input to "Amplifier out" BNC connector of control unit. Synchronization could be performed from "Trig" signal (see Appendix A).
- 5.18 Make sure that no pump laser radiation propagates inside the autocorrelator.
- 5.19 Switch power on.
- 5.20 Set the control "Hi" – "Low" as follows: For 10...1000kHz input pulse repetition rate (amplifiers) – "Low"; For >1000kHz input pulse repetition rate (generators) – "Hi". Push knobs "Amplifier" and "Generator" to select mode of operation.
- 5.21 Set-up oscilloscope sensitivity - 100 mV/cm scale.
- 5.22 To adjust retro-reflector M2 oscillation amplitude and frequency, adjust "Ampl." and "Freq." with the "Generator" knob. You should see autocorrelation functions on the oscilloscope screen (50-100msec/div) like Fig.3.
- 5.23 To maximize signal rotate focusing screw SF. (It may be necessary to reduce intensity of the input light to keep the signal less than 10V).
- 5.24 Moving retro-reflector M1 with micrometric screw find position in the middle between two end positions (correlation functions disappear in the end positions).
- 5.25 Find good position of the single autocorrelation function on oscilloscope screen using "DELAY" control.
- 5.26 To display interferometric autocorrelation function (Figure.4) set low frequency ("Freq" 2-5Hz) and big bandwidth ("Filter" -max). The autocorrelation function must be symmetric. If the function is observed to be asymmetric, the autocorrelator is either misaligned relative to the input beam or internally misaligned.

#### LONG RANGE SCANNING (UP TO 6PS)

- 5.27 The scanning range of the M2 is adjustable to 1mm which means a time delay  $>6\text{ps}$ .
- 5.28 The electrical signal ("Sin") is proportional to the mechanical position of M2.
- 5.29 Use oscilloscope in X-Y mode to increase linearity.

-----  
(Optional: The measuring converter of linear movements can be installed into AA-10D. An electronic copy signal (use out "ΔX") exactly proportional to the mechanical position of the M2 allows one to operate the oscilloscope in X-Y mode. In this case linearity is better than 1% over the whole scan).

## DETERMINATION OF PULSE DURATION

Move the distance calibrator until arrow is in the middle of scale. Attach calibrator (MH) to the optical plate using screw. Move M1 with screw (ST) and simultaneously measure change of distance with help of distance calibrator and displacement of autocorrelation function on the oscilloscope screen. Find two distances corresponding to positions of autocorrelation function at 1/2 of the maximum. Calculate the difference  $\Delta L$ . You can measure the width ( $\Delta\tau$ ) of autocorrelation function taking into account that  $15\mu\text{m}$  measuring distance corresponds to 100 fs. To get pulse width ( $\Delta t$ ) you should divide  $\Delta\tau$  by 1.41 assuming Gaussian pulse shape or divide by 1.55 assuming sech<sup>2</sup> shape.

(Roughly  $\Delta t$  (fs) =  $\Delta L$  (mkm) x 4).

In measuring a pulse that has a width corresponding to  $<30\text{fs}$ , it is important to consider possible sources of error. Due to the effect of group velocity dispersion within the BS fused silica plate 1mm-thick the measured pulse width to be broadened by  $<1\text{fs}$ . To keep this broadening at a minimum value compensation plate (CP) should be installed. To minimize dispersive effects only gold mirrors are employed.



# References

1. E. P. Ippen and C. V. Shank, in *Ultrashort Light Pulses*, S.L.Shapiro, ed. (Springer-Verlag, New York, 1977), pp.89-92.
2. J.-C. Diels and W. Rudolph, *Ultrashort Laser Pulse Phenomena: Fundamentals, Techniques, and Applications on a Femtosecond Time Scale* (Academic, San Diego, Calif., 1996), pp. 365-399.
3. J.-C. Diels, J. J. Fontaine, I. C. McMichael and F. Simoni, *Appl. Opt.* **24**, 1270 (1985).
4. P. Heinz, A. Reuther, A. Lauberean, *Optics Comms*, **97**, 35 (1993).
5. D.H. Auston, *Appl. Phys. Letts*, **18**, 249 (1971).
6. W. Leupacher, A. Pezkofer, *Appl Phys. B*, **29**, 263 (1982).
7. A. J. De Maria et al , *IEEE*, **57**, No1, 2 (1969).
8. H. Schulz, H. Schuler, T. Engers and D. Von Der Linde, *IEEE J.Quantum Electron.* **25**, 2580 (1989).
9. J.-C. Diels, J. J. Fontaine and W. Rudolph, *Revue Phys Appl.*, **22**, 1605 (1987).
10. J. G. Fujimoto, A. M. Weiner and E. P. Ippen, *Appl. Phys. Lett.*, **44**(9),832 (1984).
11. J.K.Ranka, A.L.Gaeta, A.Baltuska, M.S.Pshenichnikov, D.A. Wiersma, *Optics Letters*, **22**, No.17, 1344 (1997).

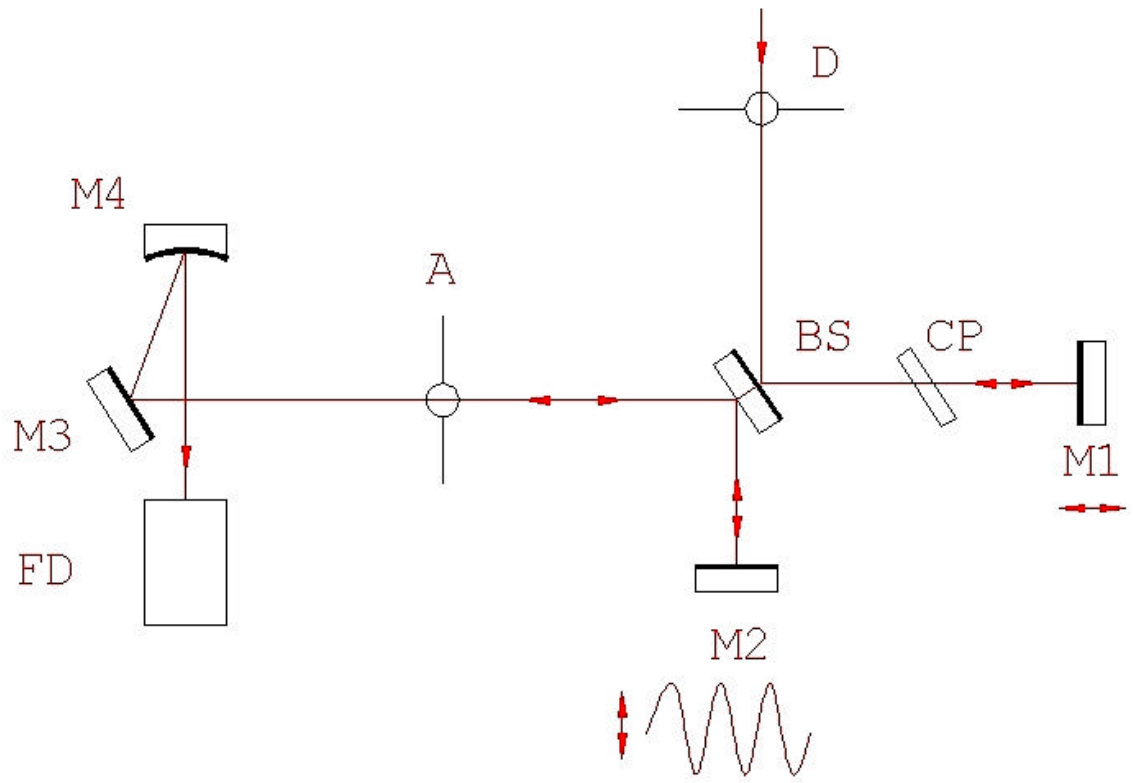

Figure.1

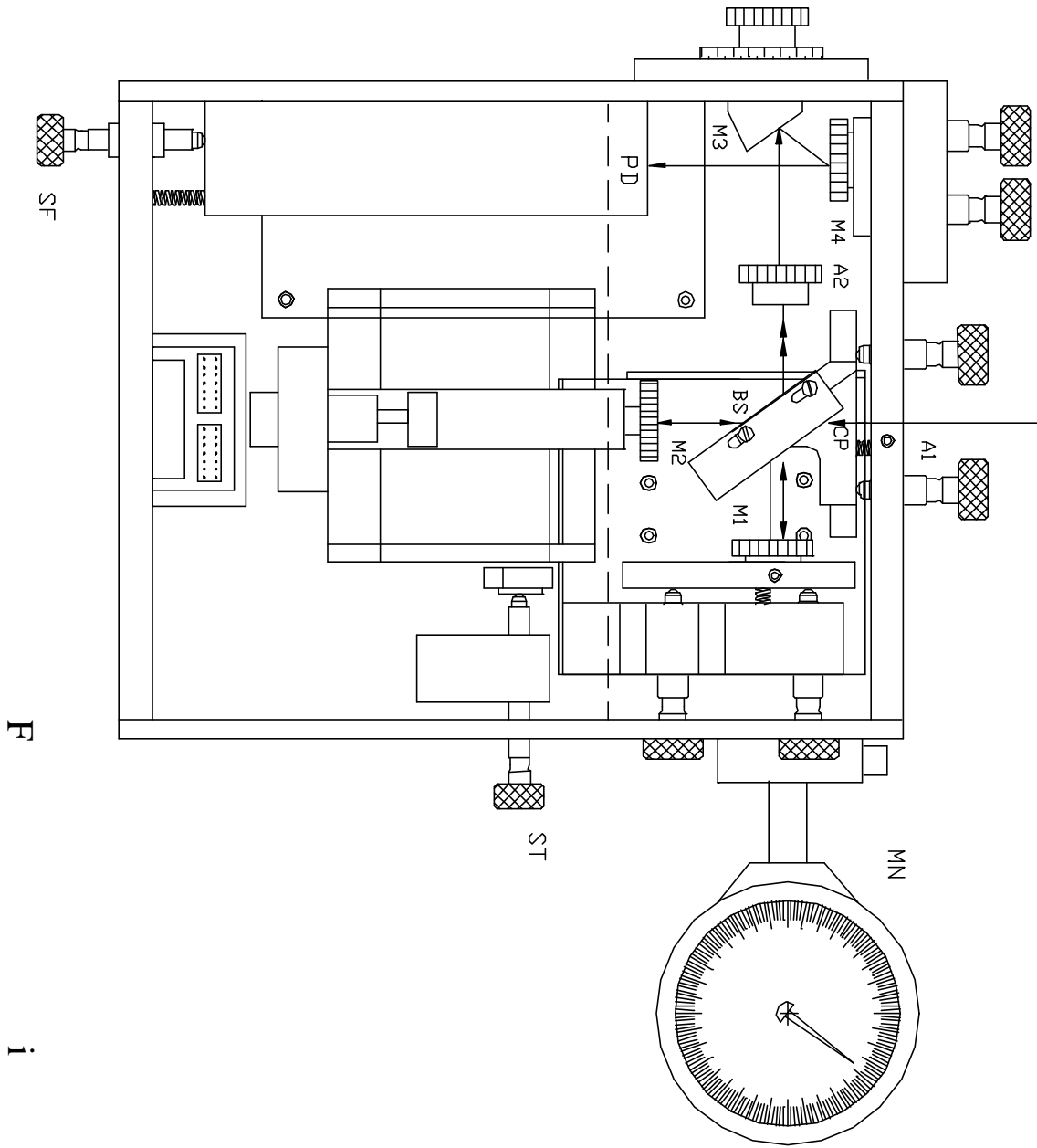

Figure.2

9

*BORDO 100.3*

- bordo4

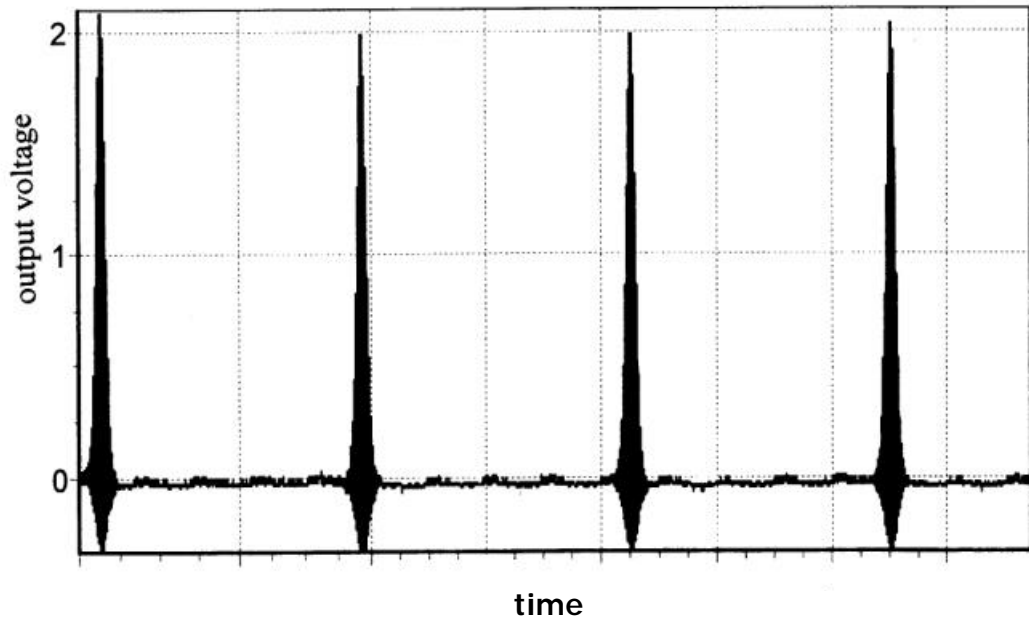

Figure.3

**BORDO 100.3**

- bordo5

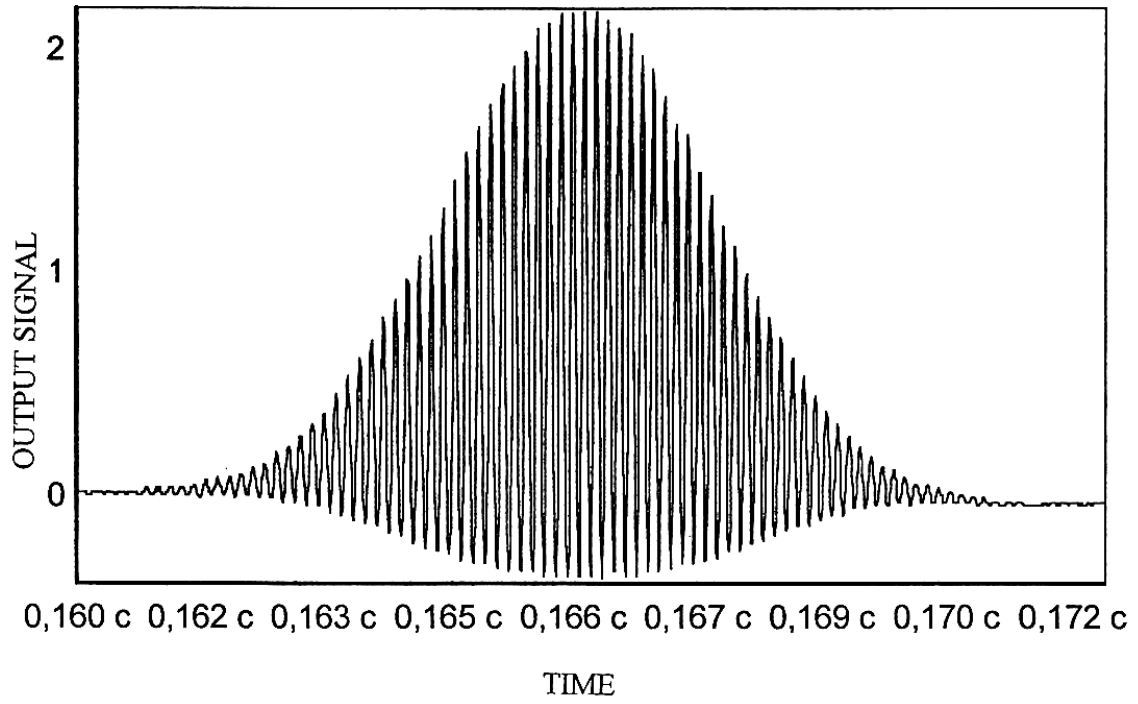

Figure.4

# Appendix A

## GENERAL INFORMATION

The AA-10DM control unit is intended for driving moving mirror actuator and sensing mechanical mirror position.

Control unit consists of sine generator of variable frequency, variable gain amplifier, output driver and inductive position sensor (optional), see Figure. A1.

Output signal amplitude and frequency are controlled by an on board CPU. Parameters are stored and recalled in/from flash memory. Generator frequency is variable in a range of 0.1...20 Hz in 42 steps; output amplitude is variable in a range 0...+8V in 50 steps. . Two front panel rotary knobs labeled «Amplifier» and «Generator» control gain, bandwidth and output sine frequency and amplitude respectively. Red LED digital display shows actual value of amplitude (0..50 in arbitrary units) and frequency (0.1...20 in Hz). Output power driver can output up to +8 V to 10 Ohm load and is short-circuit protected.

Generator outputs are:

- «Sin» - fixed amplitude + 10V sine wave, BNC type connector, placed on a rear panel.
- «Trig» - 12V amplitude logical signal. Its phase relative to output sine can be adjusted by
- «Delay» potentiometer from a front panel.

Optional: Mechanical position sensor consists of 32 kHz generator driving fixed coil and synchronous detector, sensing sample signal. Output value +10 V at «**DX**» connector corresponds to + 1 mm movement. Position sensor is static and can measure any steady mirror shift.

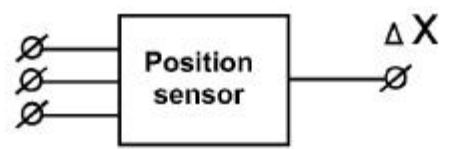
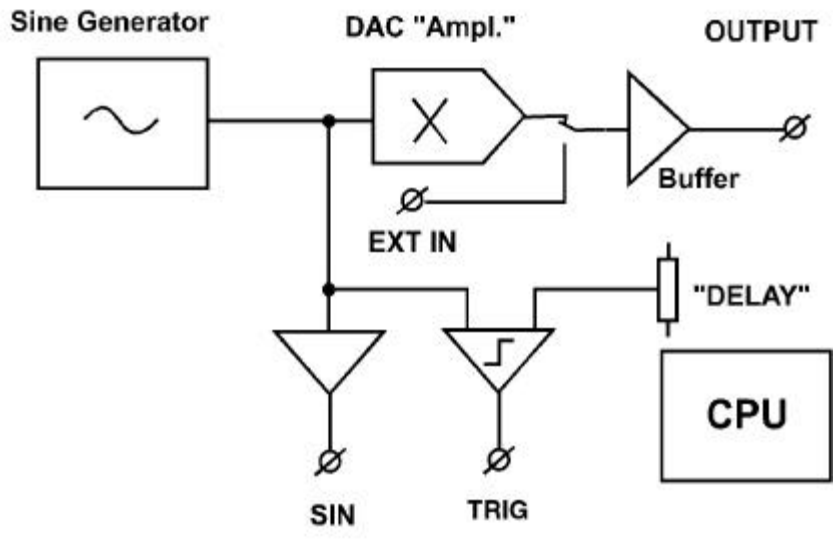

Figure. A1

## EXTERNAL CONNECTIONS AND OPERATION CONTROL

Check that power switch is set to off. Connect power cord to 100V 50-60Hz main outlet. Connect measurement equipment to output BNC connectors. Switch power on. Red display shows current values of a gain (or bandwidth) and frequency (or amplitude).

To adjust mirror oscillation amplitude, push "Generator" knob to set "Ampl" mode and rotate the knob. Right displayed value will change in a range of 0-50, corresponding to about 0-8 V output amplitude. Set value is immediately stored in a nonvolatile memory.

To adjust mirror oscillation frequency, push "Generator" knob to set «Freq» mode and rotate the knob. Right displayed value will change in a range of 0.1-20 Hz. Set value is immediately stored in a nonvolatile memory.

To adjust the gain of signal amplifier, push "Amplifier" knob to set the "Gain" mode and rotate the knob.

To adjust the bandwidth of amplifier, push "Amplifier" knob to set the "Filter" mode and rotate the knob.

Setting amplitude and frequency value; check mirror movement to not reach position limits, disturbing parasitic oscillations.

Synchronization could be performed either from «Trig», "Sin" or «DX» (optional) signals. Synchronization from first two signals is rather convenient in a case of large mirror movement range, but may be unstable due to mechanical vibrations of mirror elastic holder. Synchronization from «DX» signal avoids this error, but could be unstable in case of small oscillation amplitude. The best data acquisition method consists of PC-based 2-channel ADC board collecting data array and averaging them after acquisition.



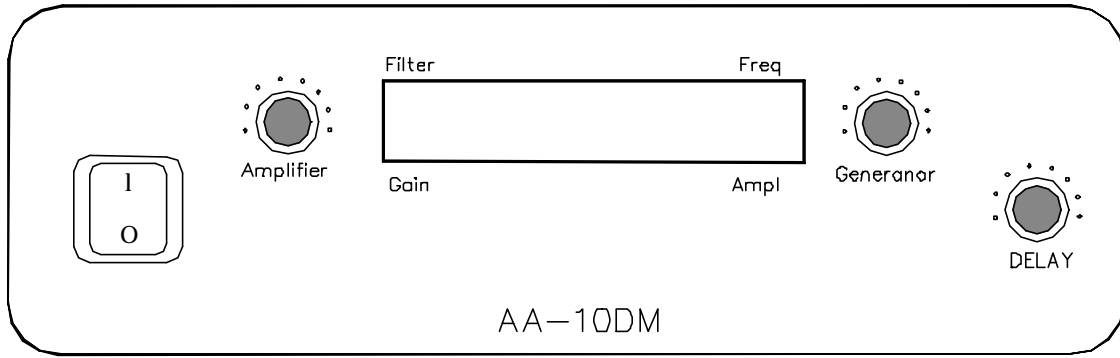

Front panel

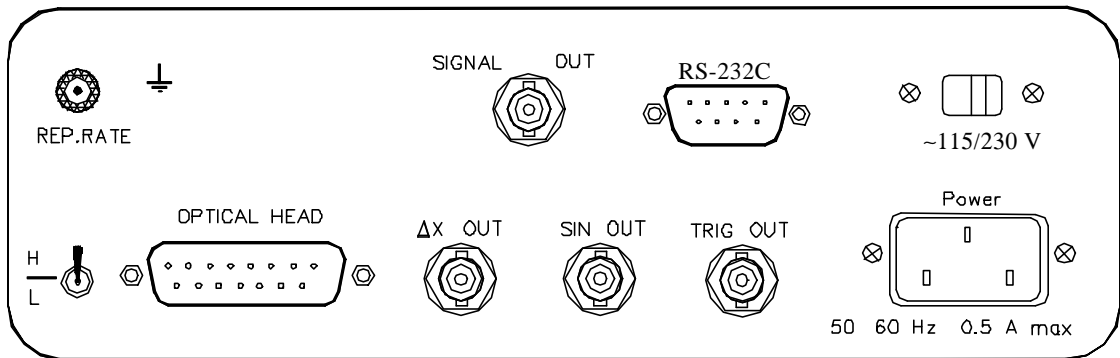

Rear panel

Figure. A2

#### SERIAL LINE OPERATION CONTROL

Generator output signal parameters could be modified via RS-232C serial line from computer or terminal. Generator is equipped with DB-9 male connector. Use null-modem cable to connect generator to PC. Line setup **9600,8,n,1**. Handshake - **none** or **XON/XOFF**. Only RxD, TxD and GND signals are required.

To set signal frequency type from terminal program Fxx or fxx and press CR. Here xx-00...42 - point number, decoded to 0.1...20Hz range via table.

To set signal amplitude type from terminal program Axx or axx and press CR. Here xx-00...50 - relative amplitude.

After transmission is complete generator sets up new parameters and displays them.



